

EuCARD WP4 - Accelerator Networks

coordinated by

Jean-Marie De Conto, Mariusz Grecki, Walter Scandale,
Peter Spiller, Ezio Todesco, Alessandro Variola, Wolfgang
Weingarten, and Frank Zimmermann

First EuCARD Annual Meeting
RAL, 14 April 2010

accelerator landscape

major events 2009-2013

LHC turn on & first physics results

FAIR & XFEL construction

major LHC upgrade (LINAC4)

decisions on LHC upgrades

decision on future Linear Collider

FLASH & CTF-3 exploitation

perfect timing for AccNet



ACCNET



Accelerator Science Networks



Coordination & Management

coordinated by

Walter Scandale, IN2P3 ; Alessandro Variola, LAL ;
Peter Spiller, GSI ; Frank Zimmermann, CERN

April 2010 changes:
Alessandro Variola
resigns; Walter
Scandale changes
affiliation to IN2P3-
CNRS, new coordinator
Peter Spiller joins



EUROLUMI

*accelerators & colliders
performance*

coordinated by

Frank Zimmermann, CERN
Ezio Todesco, CERN



RFTECH

sc & nc rf technologies

coordinated by

Jean-Marie de Conto, UJF
Mariusz Grecki, DESY
Wolfgang Weingarten, CERN

AccNet Coordinators



EUROLUMI

brings together experts in beam dynamics, magnets, collimation & RF

FAIR



LHC phase-2 upgrade paths for IP1 & 5

early separation (ES) J.-P. Koutchouk

stronger triplet magnets

small-angle crab cavity

D0 dipole

full crab crossing (FCC) L. Evans, W. Scandale, F. Zimmermann

stronger triplet magnets

small-angle crab cavity

LHC IR & beam parameter upgrade

large Piwinski angle (LPA)

wire compensator

- 50 ns spacing, longer & more intense bunches (5×10^{11} p/s/bunch)
- $\beta^* \sim 25$ cm, no elements inside detectors
- long-range beam-beam wire compensation
- novel operating regime for hadron colliders, beam generation

low emittance (LE) R. Garoby

- ultimate LHC beam (1.7×10^{11} p/s/bunch, 25 ns spacing)
- $\beta^* \sim 10$ cm
- smaller transverse emittance
- constraint on new injectors, off- β beat

CERN complex upgrade

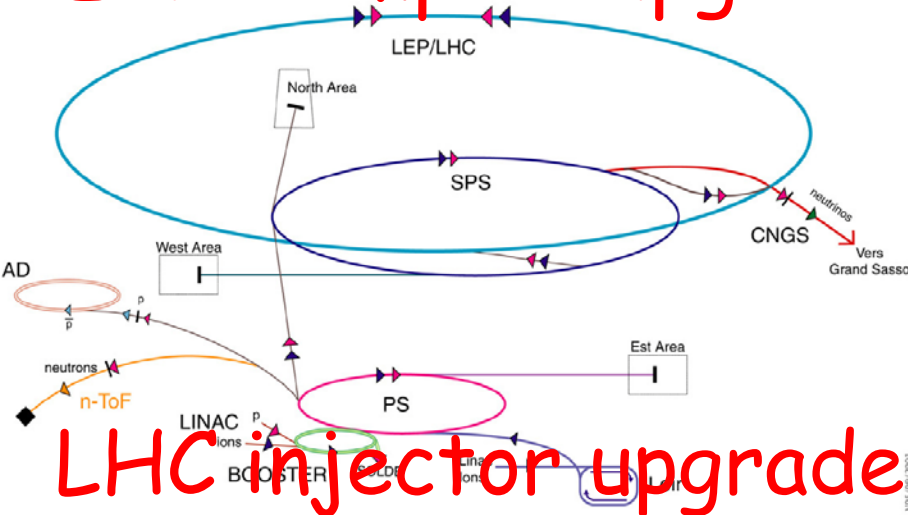

LHC injector upgrade

p (proton) (antiproton)
 ion proton/antiproton conversion
 neutrons neutrons

AD Antiproton Decelerator LHC Large Hadron Collider
 PS Proton Synchrotron n-ToF Neutrons Time of Flight
 SPS Super Proton Synchrotron CNGS Cern Neutrinos Grand Sasso

+

medical accelerators

+

plasma acceleration

EUROLUMI themes

LHC IR upgrade: IR magnet technology; heat deposition & shielding; magnet lifetime; performance reach; ...

LHC beam parameter upgrade: beam generation, beam stability; beam-beam performance & compensation; crab cavities; luminosity leveling; machine protection; collimation upgrade; crab waists; intensity limits ...

FAIR: beam losses; space-charge effects; vacuum; aperture; ramping issues; ...

CERN complex upgrade: SPS electron-cloud mitigation; impedance effects; intensity limits; beam manipulation; PS booster upgrade ; SPL ; ...

LHC energy upgrade: beam dynamics, magnets, ...

Applications for society: medical accelerators

Advanced techniques: plasma acceleration, crystal tools

RFTECH

brings together RF experts from different labs, proton & electron accelerators, CLIC and ILC, ... ; encompasses all aspects of RF technology, e.g. klystron development, RF power distribution system, cavity design, and low-level RF system, for linear accelerators, storage rings, and associated research infra-structures, including transversely deflecting (crab) cavities and financial aspects such as costing tools



XFEL

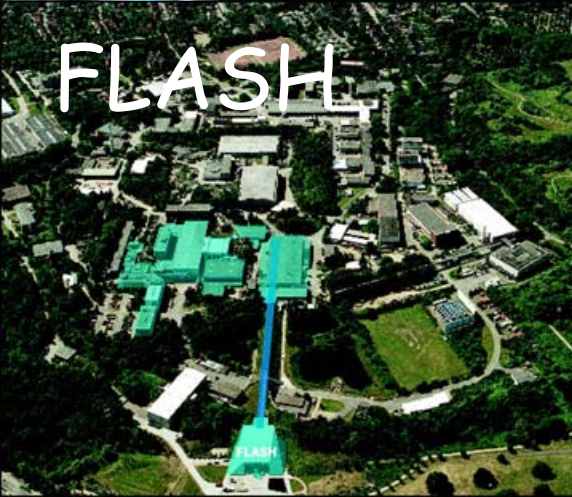

FLASH

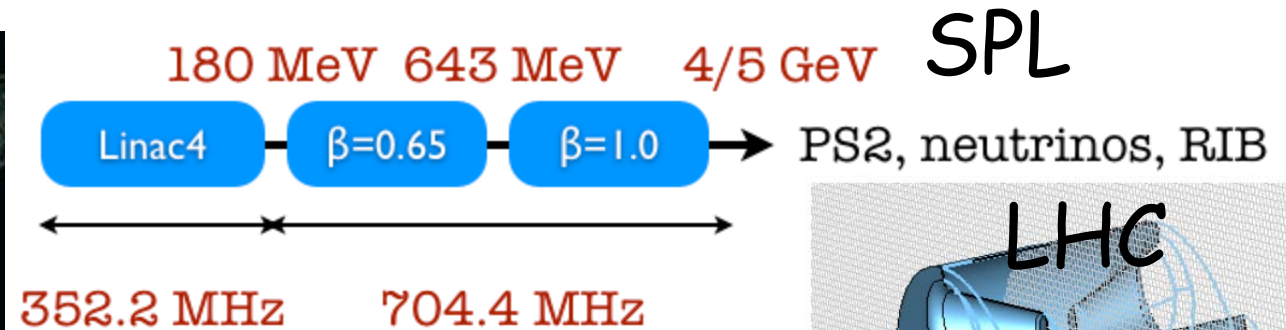

ILC

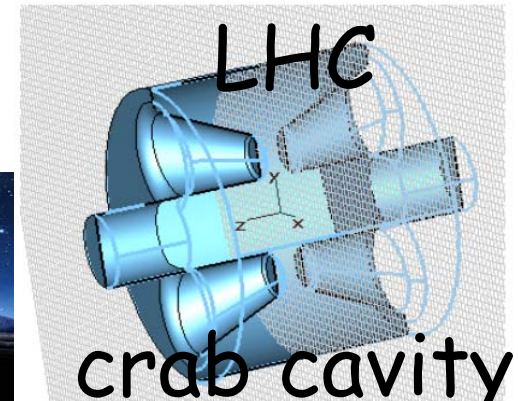

LHC
crab cavity

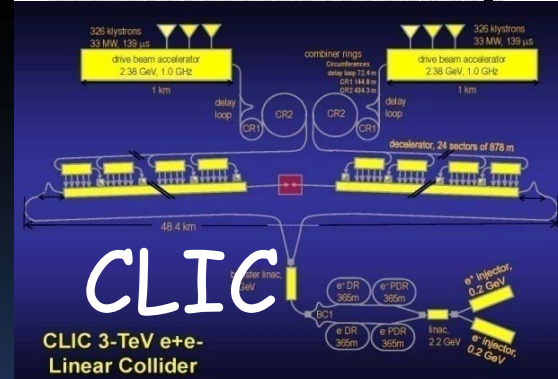

RFTECH themes

low level RF: maintain RF phase (0.03 dg) & amplitude (0.03%); minimize power; built-in diagnostics; reliability; operability; reproducibility; maintainability; good understanding; development of LLRF costing tools based on SysML model; ...

cavity design: maximize gradient; minimize breakdown; optimize efficiency; minimize cost; minimize impedance; accelerating cavities; coupler design; PETS; compact crab cavities;

high power RF: power distribution system; design integration; costing tools; ...

SRF test infrastructures: establish multi-purpose state-of-the art network of equipment for R&D and test of SRF cavities and cryo-modules within 2 years; future projects - required equipment - project descriptions

ACCNET tools



- ❑ **annual workshops**
- ❑ **topical meetings and mini-workshops**
- ❑ **capability of inviting or exchanging experts over periods of typically a week to a month**
- ❑ **exploratory studies & collaborations**
- ❑ **opportunities for students**
- ❑ **unique place of discussion with users**

→ *exchange of ideas and expertise aimed identifying the most promising strategies and technologies*

ACCNET is a catalyzer!

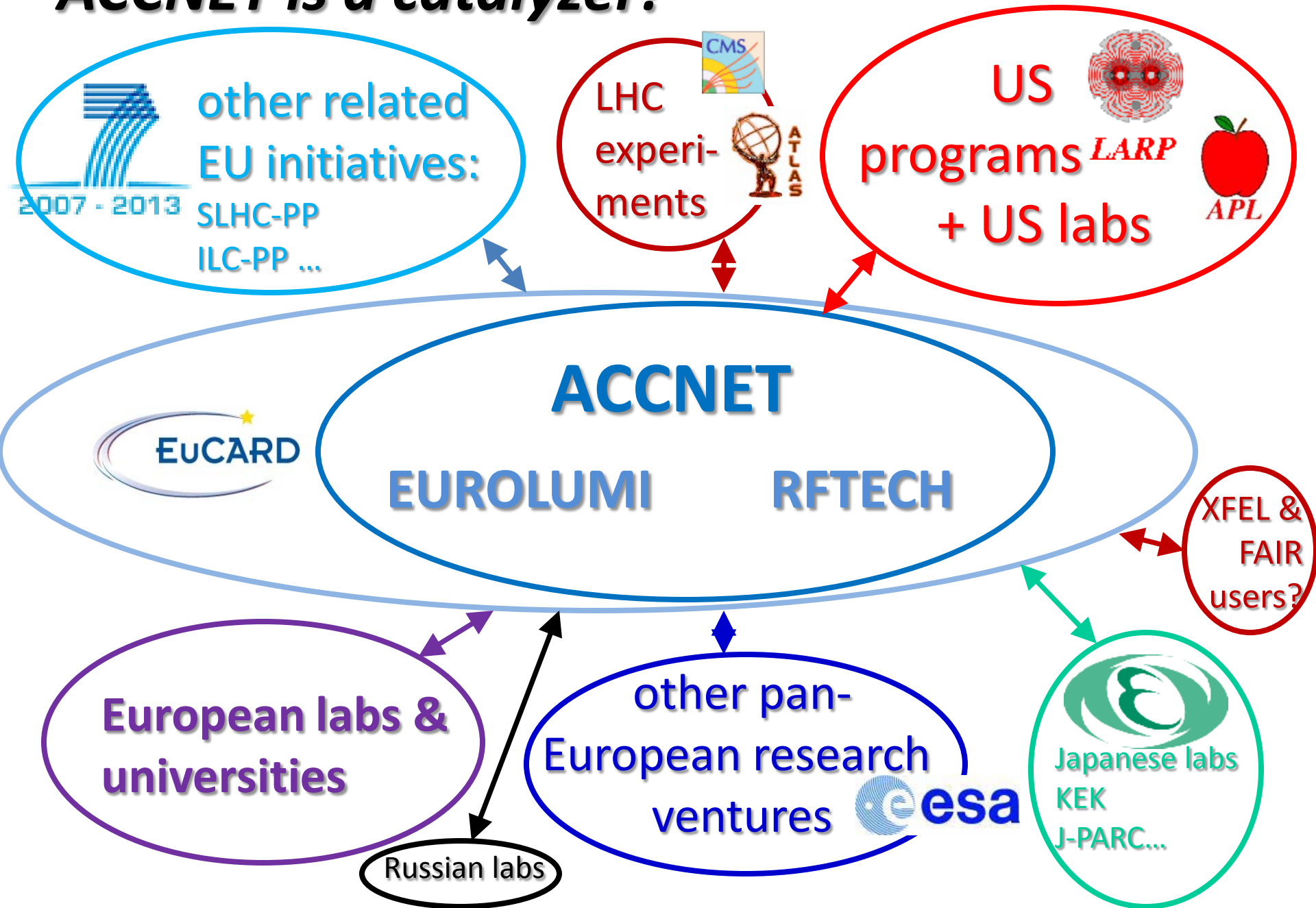

The participation is open inside and outside the consortium. A large number of institutes participate in ACCNET activities.

first ACCNET meeting: 04.12.2008



AccNet 1st-year achievements

- (invited) **talks** at **PAC 2009, EPS HEP2009 & LLRF09** conferences
- **AccNet workshop on LHC crab cavities**, LHC-CC09, September 2009
- **AccNet-EuroLumi workshop on anti-e-cloud coatings**, AEC'09, Oct '09
- **AccNet web site at LAL**
- **AccNet mailing lists**
- **contact persons** from all participating institutes for both networks
- **man power and budget plans**
- scope expansion to **plasma acceleration and medical accelerators**
- **AccNet-EuroLumi mini-Workshop on Crystal Collimation**, Nov. '09
- **AccNet-EuroLumi working meeting on proton driven plasma acceleration**, PPA'09, Dec. 2009
- **AccNet Co-Sponsored Workshop on "Physics for Health in Europe"**, Feb. 2010
- **AccNet General Steering Meeting**, 13 April 2010, RAL

AccNet publications

AccNet dissemination & outreach

- two **articles in 2nd EuCARD newsletter** (on LHC-CC09 + AccNet & on concept of proton plasma acceleration)
- one **article in CERN Courier** Feb. 2010 (on PPA'09 workshop)
- two **seminar talks** at DESY and University of Heidelberg
- CERN **Academic Training lecture series on LHC upgrade**
- presentations at **ATLAS upgrade week** and to **LHCC**
- presentations at **Chamonix'2010 LHC Performance Workshop** and to **LHC Upgrade Task Force**
- various collaboration meetings

EuCARD AccNet documents

- about 20 in total, including
 - **2 journal articles**
 - **9 conference presentations**
 - **1 PhD thesis**
 - **1 master thesis**

AccNet milestones

M.4.1.1

- 1st **RFTech videoconference steering meeting** 30 March
- **general AccNet Steering meeting** during the 2nd EuCARD Steering Committee meeting in November 2009 at Frascati.

M4.2.1:

- Instead of a general annual EuroLumi workshop, **4 topical mini-workshops** have been organized and supported during this first year (high efficiency of topical workshops; minimum interference with LHC consolidation and re-commissioning): **LHC-CC09, AEC'09, CrystalCollimation'09, PPA'09**
- **first major EuroLumi workshop in fall 2010**

M4.3.1:

- Annual **RFTECH workshop was held on 29 March 2010**

AccNet web site



**Accelerator Science
Networks**
EuroLumi and RFTech

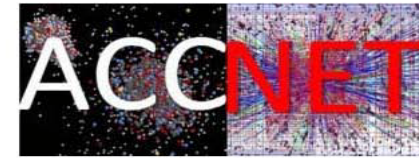

Coordinated by [W. Scandale](#)

AccNet is a Networking Activity (WP4) in the framework of [EuCARD](#)

[A. Variola](#) and [F. Zimmermann](#) (*Coordinated Accelerator R&D in Europe*)

Main Objectives	Network Structure	Activity Reports	WP4 Collaboration Workspace	Job Opportunities	Workshops	Literature and Presentations	Links
---------------------------------	-----------------------------------	----------------------------------	---	-----------------------------------	---------------------------	--	-----------------------

Notice: this site is under construction. Please accept our apologies for its incompleteness and yet missing information.

created & maintained
by Bernard Mouton,
Serge Du, Justine Yuan, &
Alessandro Variola (LAL)

AccNet is composed of two sub tasks

EuroLumi	RFTech
--------------------------	------------------------

updated by
Bernard Mouton (LAL)
and
Frank Zimmermann
(CERN)

Hot News

- 9-10 November 2009 EuCARD-AccNet-EuroLumi mini-Workshop on Crystal Collimation, at CERN - **NEW!**
- 2-4 February 2010 AccNet Co-Sponsored Workshop on "Physics for Health in Europe", CERN - **NEW!**
- spring 2010 topical workshop on plasma acceleration - **NEW!**
- spring or fall 2010 AccNet-EuroLumi workshop on LHC upgrade paths - **NEW!**

AccNet Articles in EuCARD Newsletter no 2 (September 2009):

[Start by probing the crab cavities](#)
[Breaking news for Proton "Surfatrons"](#)

AccNet deliverables - documentation

“

Authored by B. Mouton

Edited by B. Mouton

and K. Kahle

Reviewed by A. Variola

Approved by Steering

Committee

“



Grant Agreement No: 227579

EuCARD

European Coordination for Accelerator Research and Development
Seventh Framework Programme, Capacities Specific Programme, Research Infrastructures,
Combination of Collaborative Project and Coordination and Support Action

DELIVERABLE REPORT

CONTINUALLY UPDATED ACCNET, EUROLUMI AND RFTECH WEB SITES

DELIVERABLE: D4.1.1, D4.2.1, D4.3.1

Document identifier:	EuCARD-Del-D4.1.1-D4.2.1-D4.3.1-1001866-v1.0
Due date of deliverable:	End of Month 2 (May 2009)
Report release date:	xx/xx/2009
Work package:	WP4: Accelerator Science Networks EuroLumi and RFTech
Lead beneficiary:	CERN, CNRS
Document status:	Draft

Abstract:

The ACCNET web site <http://accnet.lal.in2p3.fr/> has been implemented. At the same time the two tasks EuroLumi and RFTech web pages have been integrated in the ACCNET site. This brief report describes these web sites, their scope and their structure.

AccNet EuroLumi institutes & contacts

Institute	Name	Institute	Name
<u>BNL</u>	Calaga Rama	<u>GSI</u>	Boine-Frankenheim Oliver
	Drees Angelika	<u>INFN-LNF</u>	Biagini Marica
	Fischer Wolfram		Palumbo Luigi
	Peggs Steve		Spataro Bruno
<u>CERN</u>	Bottura Luca	<u>INFN-NA</u>	Vaccaro Vittorio
	Todesco Ezio	<u>KEK</u>	Ohmi Kazuhito
	Zimmermann Frank	<u>LBNL</u>	Furman Miguel
<u>CI</u>	Chattopadhyay Swapan	<u>MPP</u>	Caldwell Allen
<u>CNRS-LAL</u>	Mouton Bernard		Xia Guoxing
	Scandale Walter	<u>TEMF</u> <u>Darmstadt</u>	Mueller Wolfgang
	Variola Alessandro		Weiland Thomas
<u>CNRS-LPSC</u>	Baylac Maud	<u>TUBE</u>	Bruns Warner
<u>CSIC - IFIC</u>	Faus Golfe Angeles		Henke Heino
<u>DESY</u>	Mais Helmut	<u>UJF</u>	De Conto Jean-Marie
<u>FNAL</u>	Bhat Chandra	<u>UOM</u>	Sammut Nicholas
	Sen Tanaji	<u>UPSA</u>	Ekelof Tord
	Shiltsev Vladimir	<u>USAN</u>	Petracca Stefania
	Valishev Alexander		

AccNet RFTech institutes & contacts

Institute	Name
BESSY Berlin	Knobloch Jens
BNL	Ben-Zvi Ilan
	Calaga Rama
CEA-DSM	Chel Stéphane
	Daël Antoine
	Devanz Guillaume
CERN	Duperrier Romuald
	Angoletta Maria Elena
	Brunner Olivier
	Calatroni Sergio
	Capatina Ofelia
	Chiaveri Enrico
	Garoby Roland
	Hofle Wolfgang
	Jensen Erk
	Junginger Tobias
	Montesinos Eric
	Ruber Roger
	Vretenar Maurizio
	Vullierme Bruno
Weingarten Wolfgang	
CI	McIntosh Peter
CNRS-IPNO	Bousson Sébastien
	Gardès Daniel
	Gassot Hui Min
CNRS-LAL	Olry Guillaume
	Mouton Bernard
Darmstadt University-IKP	Variola Alessandro
	Eichhorn Ralf

Institute	Name
WUT	Czuba Krzysztof
DESY	Elsen Eckhard
	Grecki Mariusz
	Nietubyc Robert
	Proch Dieter
ESRF	Simrock Stefan
	Jacob Jorn
FZD	Teichert Jochen
Goettingen University	Quadt Arnulf
GSI	Huelsmann Peter
IFJ PAN	Wierba Wojchiech
INFN-LNF	Ghigo Andrea
INFN-Milano	Pagani Carlo
INFN-Roma	Tazzari Sergio
Institute for Nuclear Studies, Swierk	Wronka Slawomir
Karlsruhe University?	Ustinov Alexey?
LPNHEP (IN2P3 Jussieu)	Augustin Jean-Eudes
	Debu Pascal
Rostock University	Glock Hans-Walter
Royal Holloway	van Rienen Ursula
	Molloy Stephen
TEMF Darmstadt	Mueller Wolfgang
	Weiland Thomas
TUL	Makowski Dariusz
	Napierski Andrzej
	Smage Bogna
UFJ and LPSC	De Conto Jean-Marie
Wuppertal University	Mueller Guenter

AccNet exchanges & joint studies

Mexican summer student Humberto Maury (CINVESTAV)

- **e-cloud simulations for LHC upgrade scenarios**

US-LARP physicist Chandra Bhat (FNAL)

- **generation & stability of long flat bunches for LHC**

US-LARP physicist Rama Calaga (BNL)

- **LHC crab cavities**

Austrian physicist David Seebacher (TU Graz & U. Vienna)

- **impedance of anti-e-cloud coatings**

US expert Georg Hoffstaetter, RFTech's Mariusz Grecki

- **LHC crab cavities**

German experts Allen Caldwell, Guoxing Xia (MPI Munich)

- **proton-driven plasma acceleration**

Russian and European experts A. Taratin (JINR Dubna), S.

- Dabagov (INFN-LNF) – **crystal collimation**

4 experts from DESY and WUT– **LLRF**

LHC-CC09 workshop

**LHC Crab Cavity Workshop,
jointly organized by CERN,
EuCARD-ACCNET, US-LARP,
KEK, & Daresbury
Lab/Cockcroft Institute
CERN, 16-18 September 2009**



~50 participants, LHC Crab Cavity Advisory Board established



CC-AB recommendations

- ✓ **KEKB success** → must pursue crab cavities for LHC
- ✓ **Demonstration experiments to focus on differences between electrons and protons** (e.g. effect of crab-cavity noise with beam-beam, impedance, beam loading) and on reliability & machine protection which are critical for LHC; beam test with **(KEKB?) crab cavity in another proton machine (SPS?)** useful and sufficient
- ✓ Future R&D focus: compact cavities
- ✓ **Modifications of Interaction Region 4** during the 2013/14 shutdown
- ✓ Crab cavity infrastructure **to be kept in mind for all other LHC upgrades**
- ✓ **Possible show-stopper: machine protection** - effect of cavity trip; another issue is **impedance**

*official statement from CERN management on LHC crab cavities
creation of task force for crab cavity prototype test in SPS*

CERN statement on LHC crab cavities issued after AccNet LHC-CC09 workshop

Statements on Crab Cavities from CERN

(Steve Myers, Director of Accelerators and Technology)

1. Following the success of KEKB, CERN must pursue the use of crab cavities for the LHC, since the potential luminosity increase is significant.
2. A final crab-cavity implementation for the LHC has not yet been settled. Both “local” and “global” crabbing schemes are still under consideration for the LHC upgrade phase II. Future R & D should focus on compact cavities which are suitable for both schemes.
3. One possible show-stopper has been highlighted: machine protection, which is critical for LHC. The effect of fast cavity changes needs to be looked at with high priority. Mitigation schemes such as raising the Q value of the cavity to $\sim 10^6$ (from $\sim 10^5$ at KEK) will be studied.
4. Another important issue is the impedance. Since the LHC revolution frequency changes during acceleration, the detuning of the cavity may be more difficult than was the case for KEKB, and other measures (like strong damping of the dipole mode) need to be examined.
5. High reliability of the crab cavities is essential; the trip rate should be low enough not to perturb LHC beam operation.
6. Validation cavity tests in the LHC itself are not deemed essential. It is considered plausible to install a new system in the LHC without having tested a prototype in the LHC beforehand. As in all new colliders, this has been done with many other components.
7. Demonstration experiments should focus on the differences between electrons and protons (e.g. effect of crab-cavity noise with beam-beam tune spread; impedance; beam loading) and on reliability & machine protection which are critical for the LHC.
8. A beam test with a KEKB crab cavity in another proton machine is considered useful, meaningful and sufficient (for deciding on a full crab-cavity implementation in LHC) if it addresses the differences between protons and electrons.
9. Possible modifications of LHC Interaction Region 4 during the 2013/14 shutdown should be studied to evaluate the feasibility of installing and testing crab-cavity prototypes, and of accommodating a possible global crab-cavity scheme.
10. The timing of the crab-cavity implementation should be matched to the short and long-term goals and to the overall CERN schedule, and be in phase with the experiment upgrades.
11. **The crab-cavity infrastructure should be included in all other LHC upgrades scenarios.**
12. **Crab cavities can increase the LHC luminosity without an accompanying increase in beam intensity, thereby avoiding negative side effects associated with high intensity and high stored beam energy. This opinion has been endorsed by the general-purpose high-luminosity experiments.**

CC designs presented at LHC-CC09

conventional, elliptical, “global” crab cavities

BNL

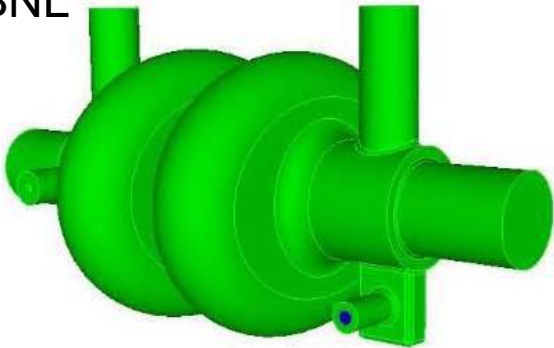

CI/DL

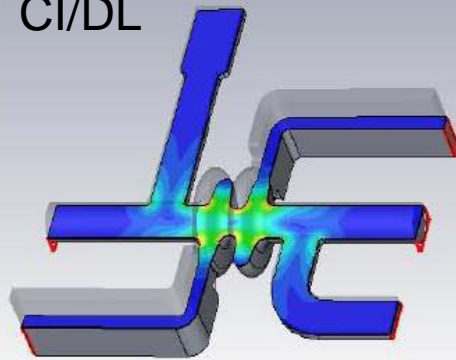

KEK

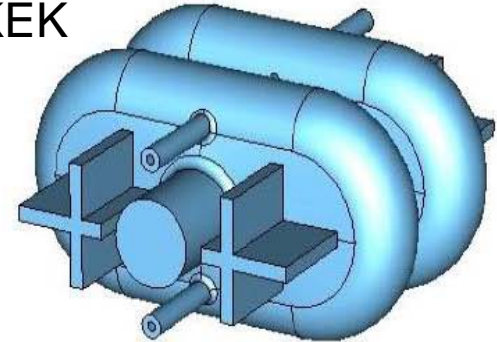

KEK

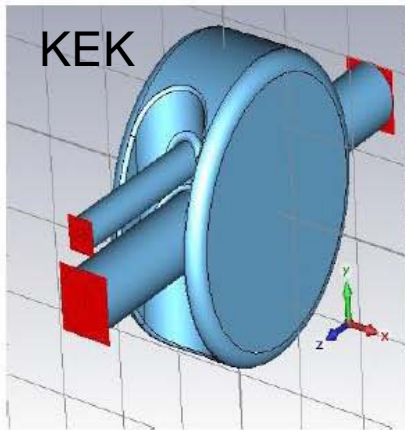

CI/DL

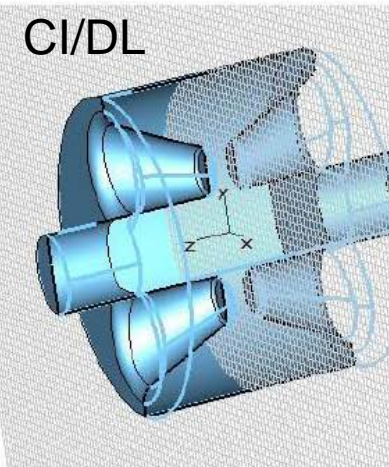

SLAC

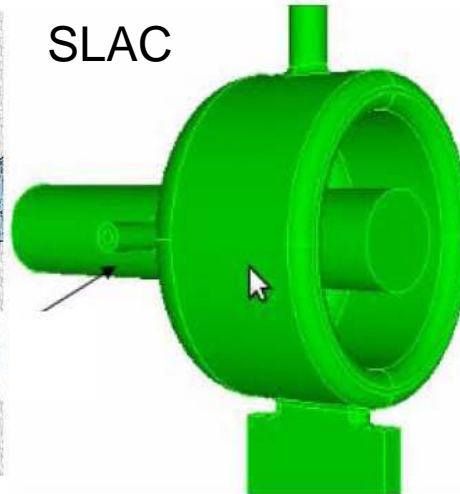

JLAB

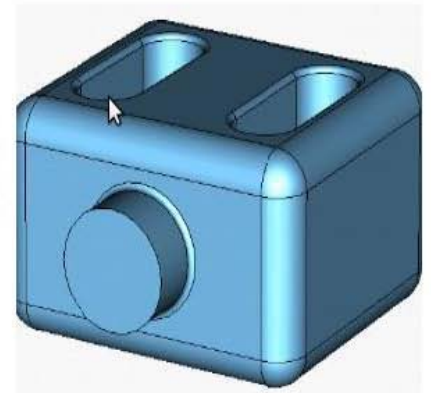

compact, “local” crab cavities

AEC'09 workshop on Anti e-Cloud Coatings

<http://indico.cern.ch/conferenceDisplay.py?confId=62873>

organized by EuCARD-AccNet-EuroLumi



<http://eucard.web.cern.ch/EuCARD/index.html>

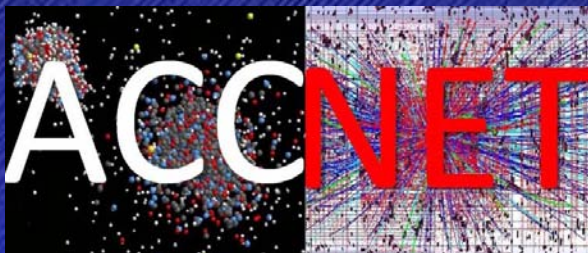

<http://accnet.lal.in2p3.fr/>



and SPS Upgrade Study Team

<http://paf-spsu.web.cern.ch/paf-spsu/>

41 participants



novel aec-coatings presented at AEC'09

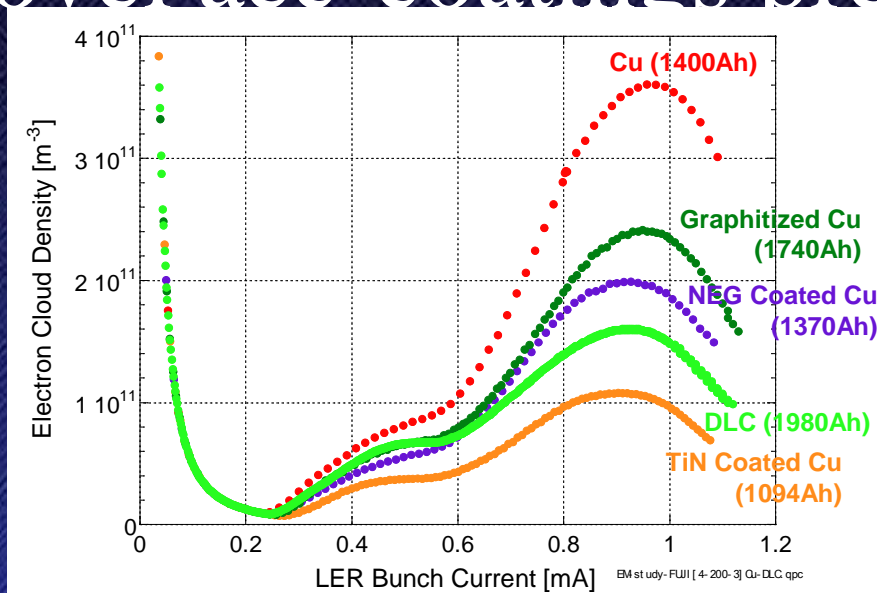

diamond-like carbon (DLC)

S. Kato
(KEK)

extremely low SEY by coating with insulating micro-particles

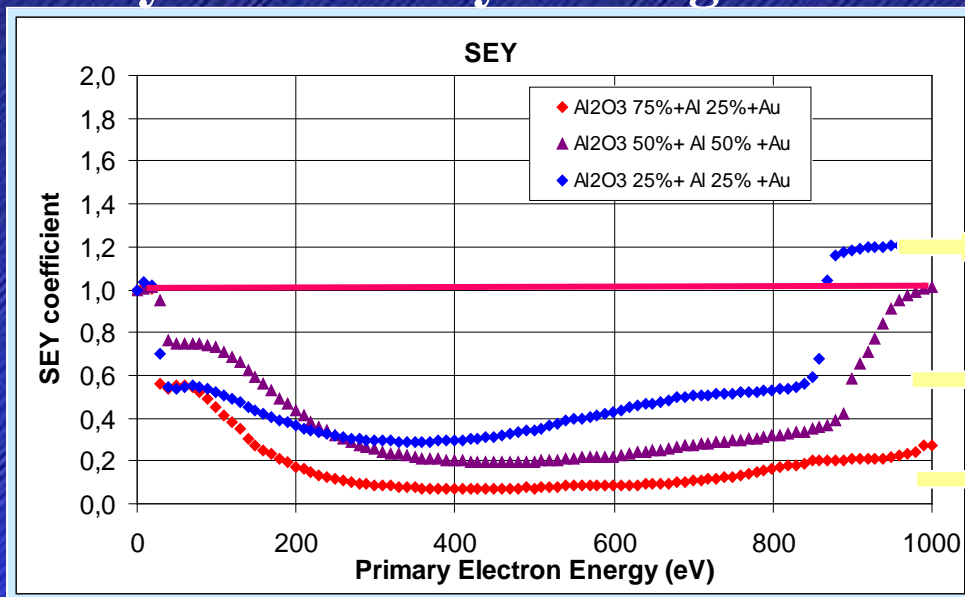

Al particle

Al₂O₃ particle

Gold coated

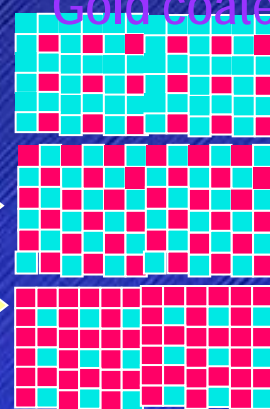

I. Montero
ICM-CSIC
(ESA research)

Surface top view

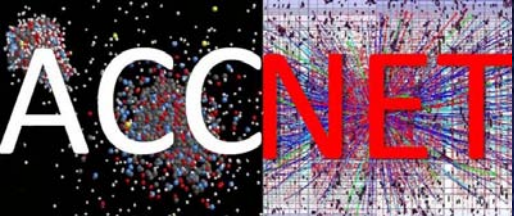

AccNet mini-workshop on crystal collimation

9-10 November '09, ~20 participants

<http://indico.cern.ch/conferenceDisplay.py?confId=71773>

topics:

SPS MDs: beam set up, detectors, data analysis,
simulations, halo cleaning

Tevatron T980 for 2009-10

Tests and test beams: IHEP activities, crystal
measurements, MVR, compact TPC at H8,
nuclear interaction, RP2 status

Future of UA9



AccNet workshop on *proton driven plasma acceleration* “PPA09”

17-18 December '09, 24 participants

CERN COURIER

<http://indico.cern.ch/conferenceDisplay.py?confId=74552>

Feb 24, 2010

Workshop pushes proton-driven plasma wakefield acceleration

AccNet in CERN Courier 2010/2

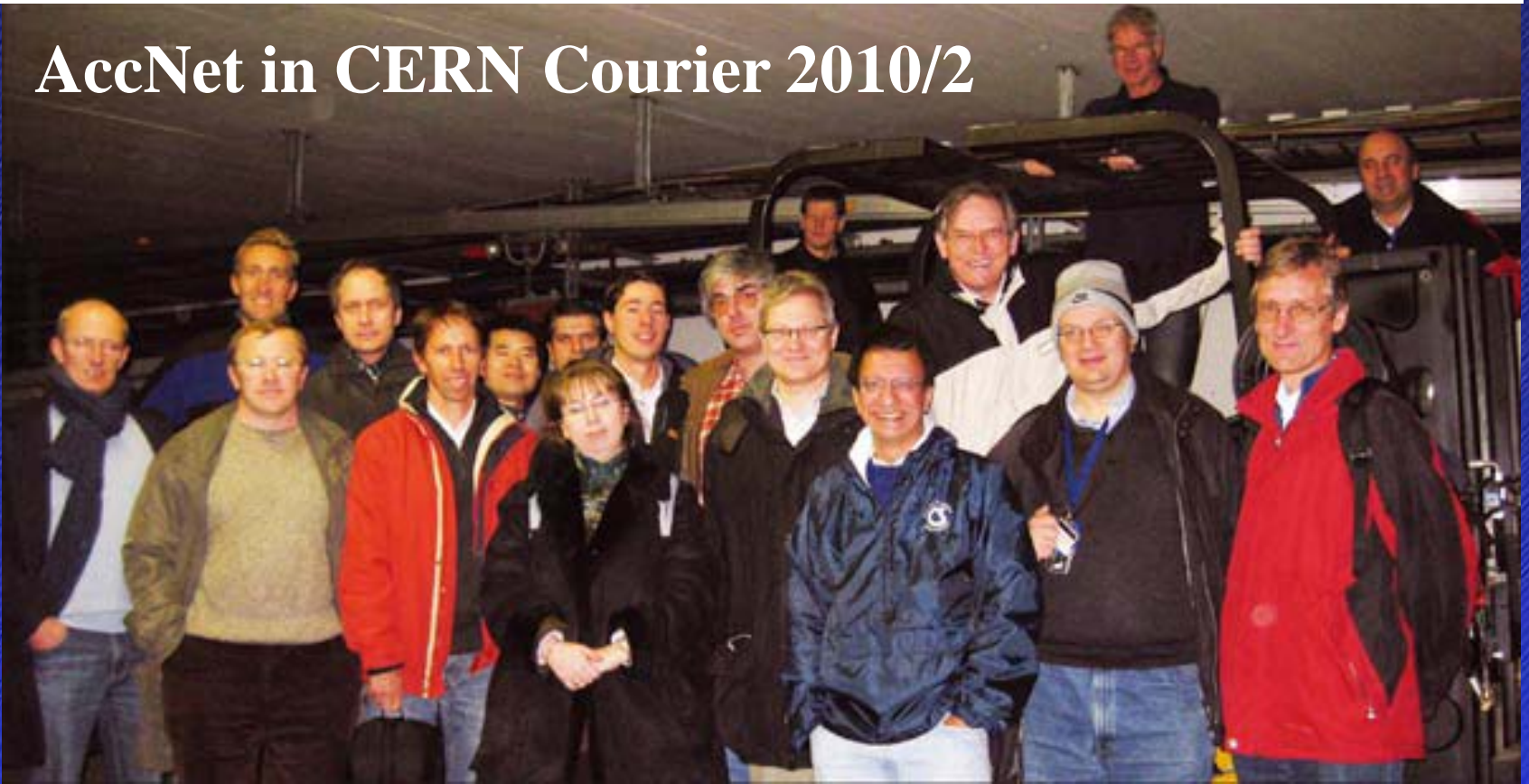

RFTech activities

joint organization of **LHC-CC09** together with EuroLumi

sLHC upgrade studies for **Superconducting Proton Linac**:

- established **contacts to European and worldwide experts on SRF**
- created **international working group on SRF cavities and accessories**

Members: CERN, CNRS-IPN-Orsay, CEA-Saclay (France), BNL (USA), TRIUMF (Canada), and University of Rostock (Germany)

This working group participated in several SPL collaboration meetings

<http://indico.cern.ch/conferenceDisplay.py?confId=63935>

First Annual RFTech Meeting

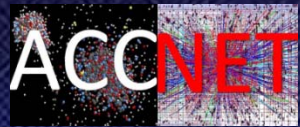

DESY, 29 March 2010



<https://indico.desy.de/conferenceDisplay.py?confId=2831>

17 participants (DESY, CERN, TUD, UROS, ASTeC, LPSC, UFJ, ESS, U London, TUL, UG, SINS) organized by M. Grecki, J.-M. De Conto, W. Weingarten & DESY

Spiral-2 couplers, SPI simulations & measurements, FLASH full beam loading, LHC LLRF, xTCA, high reliability digital system, HIE ISOLDE cavity & test cryostat, TUD SRF test stand, LHC crab cavities, RF costing tools, SRF test & R&D infrastructure

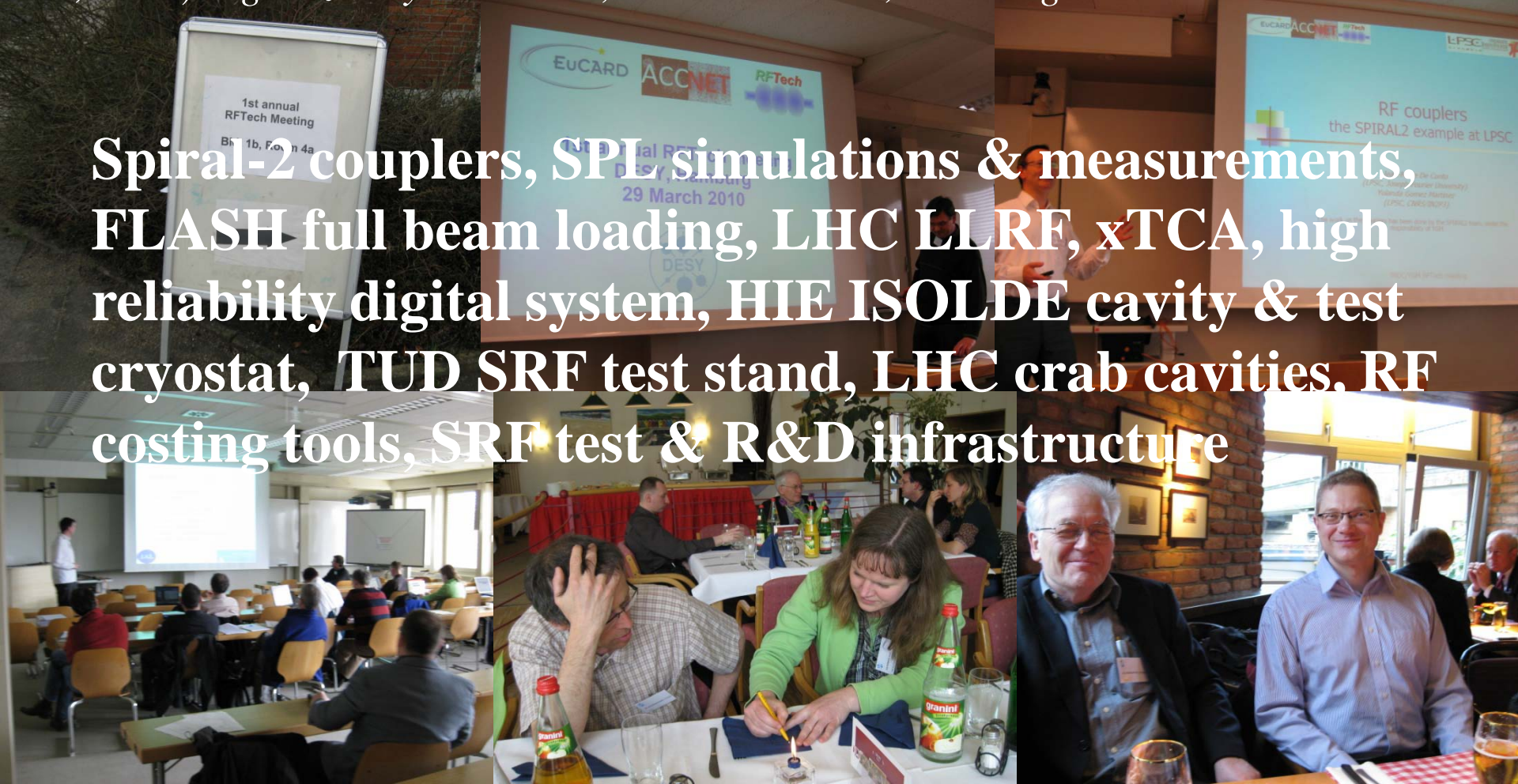

AccNet publications & talks – 1

F. Zimmermann, CERN, “[CERN Upgrade Plans for the LHC and Its Injectors](#)”, Proceedings **EPS HEP2009** Krakow 17 July 2009

C. Bhat, FNAL; F. Caspers, H. Damerau, S. Hancock, E. Mahner, F. Zimmermann, CERN, “[Stabilizing Effect of a Double-Harmonic RF System in the CERN PS](#)”, **PAC'09 Vancouver**

R. Calaga, R. De-Maria, BNL; R. Assmann, J. Barranco, F. Caspers, E. Ciapala, T. Linnecar, E. Metral, Y. Sun, R. Tomas, J. Tuckmantel, T. Weiler, F. Zimmermann, CERN; N. Solyak, V. Yakovlev, FNAL; Y. Funakoshi, N. Kota, O. Yukioishi, A. Morita, Y. Morita, KEK; G. Burt, Lancaster U; J. Qiang, LBNL; P. A. McIntosh, DL/ASTeC); A. Seryi, Z. Li, L. Xiao, SLAC, “[Status of LHC Crab Cavity Simulations and Beam Studies](#)”, **PAC'09 Vancouver**

Y.-P. Sun, F. Zimmermann, R. Tomas, “[Tune Shift Due to Crossing Collision and Crab Collision](#)”, **PAC'09 Vancouver**

Y.-P. Sun, R. Assmann, J. Barranco, R. Tomas, T. Weiler, F. Zimmermann, CERN; R. Calaga, BNL; A. Morita, KEK, “[Study with One Local Crab Cavity at IR4 for LHC](#)”, **PAC'09 Vancouver**

J.P. Koutchouk, F. Zimmermann, “[LHC Upgrade Scenarios](#)”, **PAC'09 Vancouver**

AccNet publications & talks – 2

Krzysztof Czuba, [Timing and Synchronization \(Tutorial/Overview\)](#), **LLRF09**, Tsukuba, 19-22 October 2009

M. Grecki, [Piezo Control for LFD Compensation](#), **LLRF09**, Tsukuba, 19-22 October 2009

Waldemar Koprek, [ACTA-based LLRF System for XFEL - Demonstration at FLASH](#), **LLRF09**, Tsukuba, 19-22 October 2009

C. Bhat, [LPA Scheme for the LHC Luminosity Upgrade \(updated pdf\)](#), **CERN Accelerator Physics Forum** 13 August 2009

H. Maury Cuna, [Study of the Heat Load due to the Electron Cloud in the LHC and in Higher-Luminosity LHC Extensions](#), **Master Thesis** U. Merida, August 2009

H. Maury Cuna, [Study of the Electron Cloud Heat Load in the LHC](#), CERN LCU Meeting, 28 July 2009

Yi-Peng Sun (孙一鹏), Ralph Assmann, Javier Barranco, Rogelio Tomás, Thomas Weiler, Frank Zimmermann, Rama Calaga, Akio Morita (森田 昭夫), [Beam dynamics aspects of crab cavities in the CERN Large Hadron Collider](#), **Phys. Rev. ST Accel. Beams** **12**, 101002 (2009)

AccNet publications & talks – 3

- G. Sterbini, Early Separation Scheme for LHC Luminosity Upgrade, **PhD Thesis**, EPFL
- F. Zimmermann, “Ingredients (necessary ones and desirable one) of a phase II upgrade,” **LHC Upgrade Task Force**, 26 February 2010
- F. Zimmermann, “Phase-2 Scenarios,” **LHCC Upgrade Review**, 16 February 2010
- F. Zimmermann, [Parameter space beyond \$10^{34}\$ \(paper\)](#), **LHC Performance workshop, Chamonix**, 25-29 January 2010
- F. Zimmermann, [Update on LHC Upgrade Plans](#), [ATLAS Upgrade Week](#), CERN, Tuesday 10 November 2009
- F. Zimmermann, A. Variola, W. Scandale, [EuCARD WP4 Accelerator Networks \(pdf\)](#), Report at 3rd **EuCARD Steering Committee Meeting** Frascati, 4 Nov. 2009
- Y.-P. Sun (孙一鹏), R. Assmann, R. Tomás, and F. Zimmermann, [Crab dispersion and its impact on the CERN Large Hadron Collider collimation](#), **Phys. Rev. ST Accel. Beams** **13, 031001 (2010)**
- Y.-P. Sun, B. Auchmann, S. Fartoukh, M. Giovannozzi, S. Russenschuck, R. Tomás, F. Zimmermann, Impact of CMS Stray Field on the Large Hadron Collider Beam Dynamics and Thin Solenoid in SixTrack, **LHC-Project-Note-426** (2009)

AccNet in EuCARD Newsletter no. 2

F. Zimmermann, K. Kahle, CERN, ["Start by probing the crab cavities"](#)

A. Caldwell, G. Xia, MPI München; K. Lotov, BINP; A. Pukhov, Heinrich-Heine-Universität Düsseldorf; R. Aßmann, K. Kahle, F. Zimmermann, CERN, ["Breaking news for Proton "Surfatrons" "](#)

Start by probing the crab cavities



Frank Zimmermann talks about how the AccNet Accelerator Networking activities have begun with the recent crab cavities workshop at CERN. [Read more >>](#)

Breaking news for Proton "Surfatrons"

Exciting and promising findings published by Allen Caldwell and others call for a demonstration experiment for proton driven plasma wakefield acceleration. [Read more >>](#)



Physics for Health in Europe workshop

– with AccNet participation

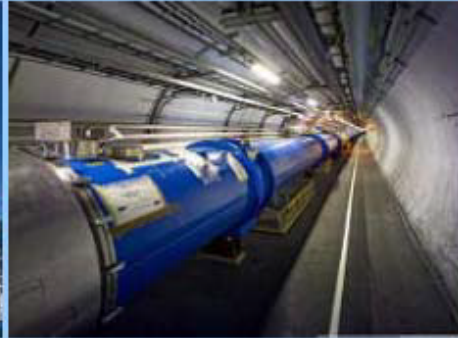

PHYSICS FOR HEALTH IN EUROPE WORKSHOP

(Towards a European roadmap for using physics tools in the
development
of diagnostics techniques and new cancer therapies)

2-4 February 2010

CERN is pleased to announce the first workshop on *Physics for Health in Europe*, which will be held at CERN, Geneva, Switzerland, on 2- 4 February 2010.

The purposes of the workshop are to review the progress in the domain of physics applications in life sciences, stimulate the exchange between different teams and indicate the subjects most suitable for further studies in diagnosis and therapy. The workshop will explore synergies between physics and physics spin-offs to fight disease with a focus on radiobiology, accelerators, radioisotope production, detectors, and use of IT. Participants are invited to share their research, discuss challenges and new developments for building a Europe-wide perspective.

AccNet plans for 2010

future AccNet workshops

- Topical workshop on **LHC energy upgrade**, together with HFM?
 - magnets for arcs and insertions, cryogenics, and vacuum pipe
- **“EuroLumi 2010”**, November or December 2010
 - LHC limitations, LHC luminosity upgrade, LHC energy upgrade, SPS upgrade, PS Booster upgrade, FAIR challenges
- Mini workshop on **LHC crab cavities**, end of 2010
- AccNet(-EuroLumi) co-sponsored **plasma acceleration** workshop
- **Crystal collimation** mini-workshop
- mini-workshop on **medical accelerators**
- **RFTech annual meeting** at PSI, end of 2010
- AccNet(-RFTech) co-sponsored **MIXDES** conference, Wroclaw, June

major reviews of LHC upgrade scenarios

- beam parameters, magnet parameters, collimation limits
- luminosity evolution, injector upgrade path, energy upgrade
- intensity & luminosity limitations

AccNet highlights talks at EuCARD 2010

**implementation strategy for LHC crab
crossing**

Rama Calaga (BNL, US-LARP & EuCARD)

proton driven plasma wave acceleration

Allen Caldwell (MPI Munich)

AccNet success indicators

excellent attendance to AccNet workshops
from many European labs, universities, US laboratories,
Japan, international organizations

impact:

- on most relevant topics
- initiated crab-cavity program for LHC
- novel anti e-cloud coating techniques

high cost efficiency

exchange of 13 expert visitors

two theses, 6 conf. papers, 2 journal articles

AccNet conclusions

AccNet had an excellent start

EuroLumi gives input to LHC upgrade

Crab Cavity Advisory Board,
endorsement of LHC crab cavities,
task force preparing SPS crab-cavity tests,
“LPA” scenario, novel e-cloud mitigation techniques,
revisions of LHC upgrade plans, energy upgrade

RFTech approaching cruising speed

AccNet is breaking new grounds

medical accelerators

plasma acceleration, crystal collimation

Ambitious programme for 2010

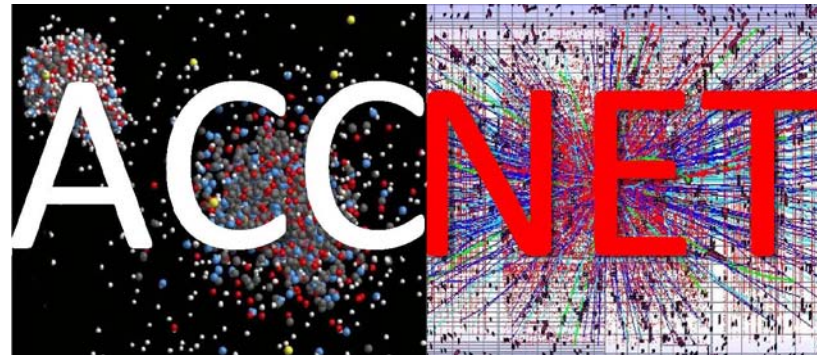

makes a difference

*for accelerators in Europe
and around the world*

Appendix

*AccNet
expenses & deliverables*

AccNet expenses

per diem for **Mexican CINVESTAV visitor** H. Maury (2 months)

travel support of **CCAB member** Georg Hoffstaetter
for LHC-CC09

travel support of **expert** David Seebacher for AEC'09

travel support for **crystal experts** (A. Taratin, S. Dabagov)

moderate **support for** LHC-CC09 and AEC'09 **workshops**

travel expenses for 4 persons (DESY, WUT) attending **LLRF'09**

travel costs for **2nd SC mtg** and **EuCARD annual meeting**

others ?

AccNet deliverables

D.4.1.1 - Continually updated **AccNet web site**

<http://accnet.lal.in2p3.fr/>)

D.4.2.1 - A continually updated **EuroLumi web site**

(<http://accnet.lal.in2p3.fr/Tasks/Eurolumi/>)

D.4.3.1 - A continually updated **RFTech web site**

(<http://accnet.lal.in2p3.fr/Tasks/Rftech/>)

The AccNet web sites are documented in a **report**

<https://edms.cern.ch/file/1001866/4/EuCARD-Del-D4.1.1-D4.2.1-D4.3.1-1001866-v3.0.pdf>

The completed deliverables are publicly available from the web link

<http://cern.ch/EuCARD/about/results/deliverables/> .